

S300SX3

320 - 800 HP Turbo



FEATURES

- Twin hydrodynamic journal bearings
- Extended tip technology compressor wheel
- Twin scroll turbine housing options available
- Adjustable compressor and turbine housing orientation
- Compressor cover recirculation grooves



TURBO FRAME DIMENSIONS

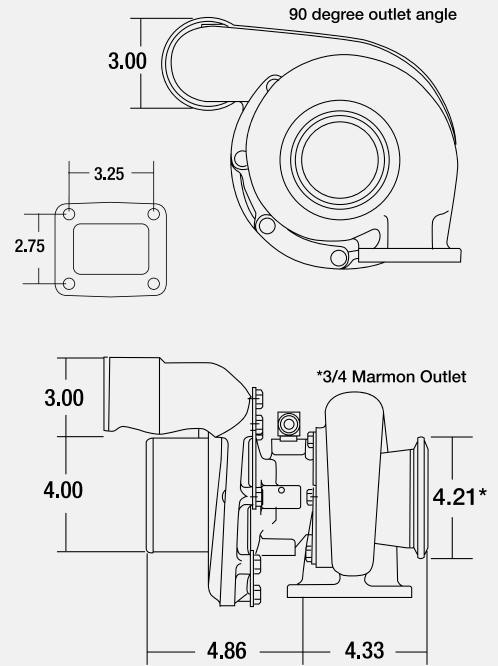

| Turbo Part # | Comp. Wheel O.D. (in) | Comp Wheel O.D. (mm) | Comp Wheel Inducer Dia. (in) | Comp Wheel Inducer Dia. (mm) | Turbine Wheel O.D. (in) | Turbine Wheel O.D. (mm) | Turbine Wheel Exducer (in) | Turbine Wheel Exducer (mm) | Turbine Housing A/R | Cartridge Assembly | Service Kit (Standard) | Service Kit (360° thrust bearing) |
|--------------|-----------------------|----------------------|------------------------------|------------------------------|-------------------------|-------------------------|----------------------------|----------------------------|---------------------|--------------------|------------------------|-----------------------------------|
| 177280 | 3.29 | 83.47 | 2.36 | 60.03 | 3.00 | 76.20 | 2.66 | 67.56 | 0.88 | 171901 | 318393 | 13007110005 |
| 177283 | 3.44 | 87.37 | 2.48 | 62.99 | 3.00 | 76.20 | 2.66 | 67.56 | 0.88 | 176648 | 318393 | 13007110005 |
| 177284 | 3.60 | 91.44 | 2.60 | 66.11 | 3.14 | 79.76 | 2.89 | 73.37 | 0.91 | 176650 | 318393 | 13007110005 |

COMPRESSOR MAP / APPLICABLE TO PART NUMBER 177283

Comp. Wheel Inducer Dia. (mm) 62.99
Comp. Wheel Outer Dia. (mm) 87.37

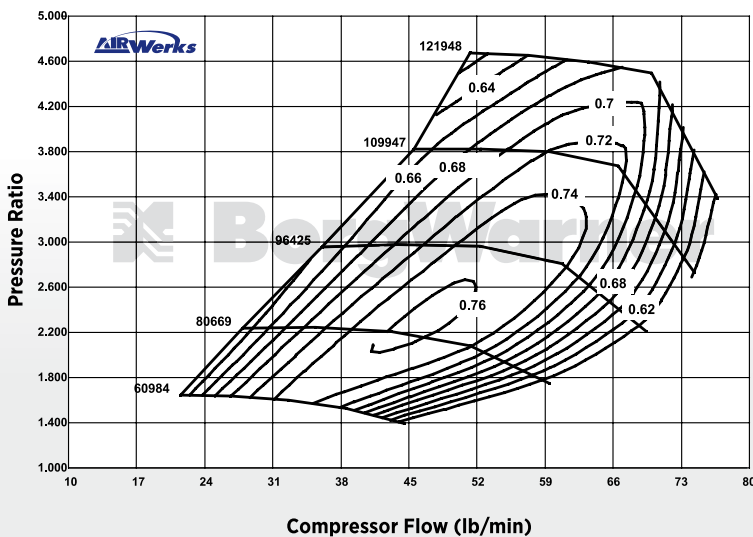

TURBINE HOUSING

| Part # | A/R | Inlet Configuration | Notes |
|--------|------|---------------------|--------------------------------|
| 177211 | 0.88 | Volute, Open Flow | T4 Inlet 80mm Turbine Wheel |
| 177208 | 0.91 | Volute, Twin Flow | |
| 179905 | 1.00 | Volute, Twin Flow | |
| 177210 | 0.88 | Volute, Open Flow | 76mm Turbine Wheel |
| 177207 | 0.91 | Volute, Twin Flow | |
| 177209 | 1.00 | Volute, Twin Flow | |