

S200SX

220 - 580 HP Turbo



FEATURES

- Twin hydrodynamic journal bearings
- Extended tip technology compressor wheel
- Twin scroll turbine housing
- Adjustable compressor and turbine housing orientation



TURBO FRAME DIMENSIONS

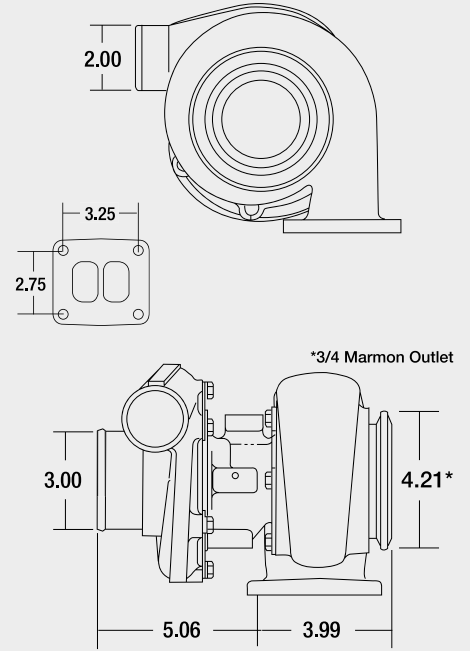

Turbo Part #	Comp. Wheel O.D. (in)	Comp Wheel O.D. (mm)	Comp Wheel Inducer Dia. (in)	Comp Wheel Inducer Dia. (mm)	Turbine Wheel O.D. (in)	Turbine Wheel O.D. (mm)	Turbine Wheel Exducer (in)	Turbine Wheel Exducer Dia (mm)	Turbine Housing A/R	Turbine Inlet	Cartridge Assembly	Service Kit
177258	2.74	69.57	1.81	45.90	2.74	69.56	2.42	61.43	0.83	VTF	176639	318383
177267	2.74	69.57	1.95	49.56	2.74	69.56	2.42	61.43	1.09	VTF	176642	318383
177257	2.74	69.57	2.00	50.72	2.74	69.56	2.42	61.43	0.83	VTF	176638	318383
177268	3.00	76.20	2.20	55.80	2.74	69.56	2.42	61.43	1.22	VTF	176637	318383
178034*	3.00	76.20	2.20	55.80	2.74	69.56	2.42	61.43	1.22	VTF	N/A	318383
178042*	3.00	76.20	2.20	55.80	2.74	69.56	2.42	61.43	1.27	VTF	N/A	318383

* Compressor inlet diameter 4.00"

COMPRESSOR MAP / APPLICABLE TO PART NUMBER 177268

Comp. Wheel Inducer Dia. (mm) 55.80
Comp. Wheel Outer Dia. (mm) 76.20

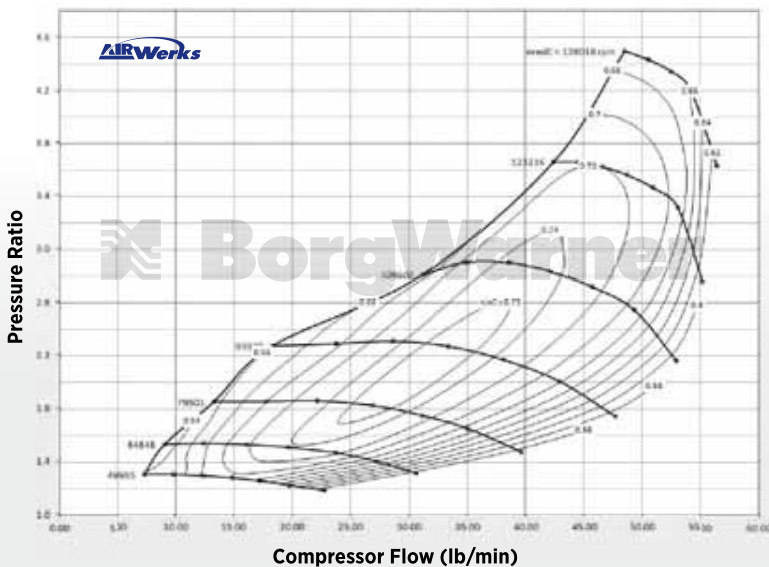

TURBINE HOUSING

Part #	A/R	Inlet Configuration	Notes
177191	0.83	Volute, Twin Flow	T4 Bolt Pattern T3 Volute Opening 70mm Turbine Wheel
177193	1.00		
177196	1.09		
177192	1.15		
177194	1.22		
178331	1.27		