

# GTX5018R

Horsepower: 950 - 1600  
 Displacement: 2.8L - 11.0L

**Honeywell**

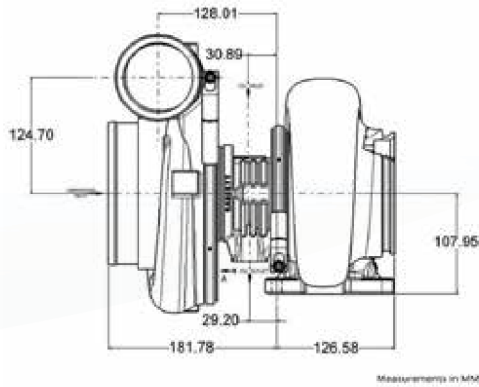

## COMPRESSOR MAP

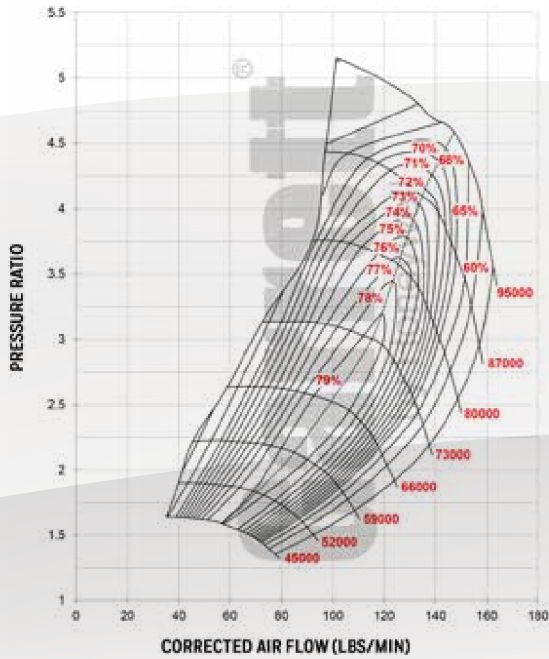

## FEATURES:

- ◆ FEATURES ORIGINAL GTX COMP WHEEL AERODYNAMICS
- ◆ NEW FULLY-MACHINED SPEED SENSOR PORT. DETAILS ON PG. 56
- ◆ SUPER CORE AND TURBINE KIT SOLD SEPARATELY
- ◆ V-BAND COMPRESSOR OUTLET CONFIGURATION
- ◆ LIGHTWEIGHT BILLET BACKPLATE

## EXHAUST FLOW CHART

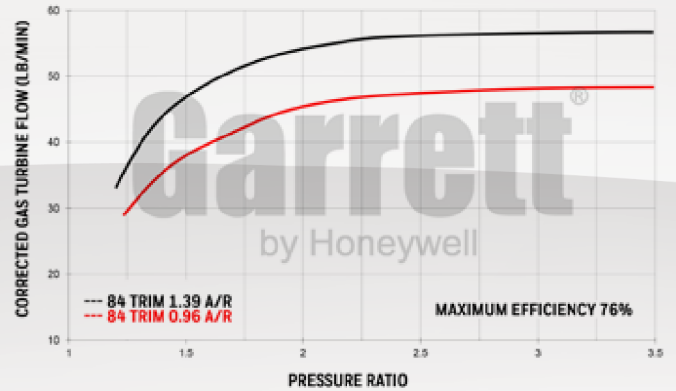

Super Core Reference Data		Compressor				Turbine		
Super Core PN	CHRA	Inducer	Exducer	Trim	A/R	Inducer	Exducer	Trim
804878-5024S	769210-0039	88mm	118mm	56	0.69	99mm	91mm	84
Notes: Super Core and Turbine Kit Sold Separately		Turbine Kit PN	A/R	Inlet	Outlet	Wastegate	Divided	Trim
		761208-0030	0.96	T6	V-Band	Free Float	N	84
		761208-0033	1.39	T6	V-Band	Free Float	N	84

**Garrett**  
 by Honeywell