

GTX5008R

Horsepower: 720 - 1270
Displacement: 2.5L - 10.0L

Honeywell

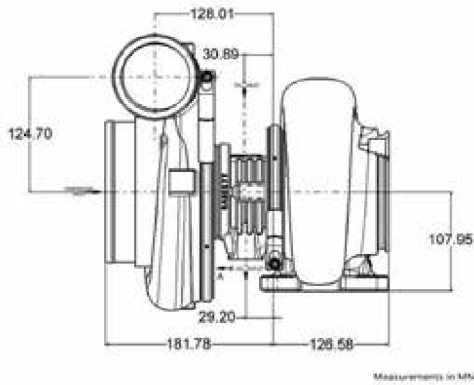

COMPRESSOR MAP



FEATURES:

- ◆ FEATURES ORIGINAL GTX COMP WHEEL AERODYNAMICS
- ◆ NEW FULLY-MACHINED SPEED SENSOR PORT. DETAILS ON PG. 56
- ◆ SUPER CORE AND TURBINE KIT SOLD SEPARATELY
- ◆ V-BAND COMPRESSOR OUTLET CONFIGURATION
- ◆ LIGHTWEIGHT BILLET BACKPLATE

EXHAUST FLOW CHART

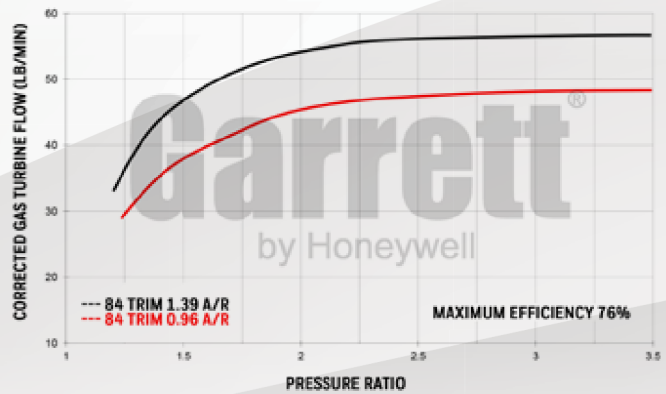

Super Core Reference Data		Compressor				Turbine		
Super Core PN	CHRA	Inducer	Exducer	Trim	A/R	Inducer	Exducer	Trim
804878-5020S	769210-0035	80mm	108mm	55	0.69	99mm	91mm	84
Notes: Super Core and Turbine Kit Sold Separately		Turbine Kit PN	A/R	Inlet	Outlet	Wastegate	Divided	Trim
		761208-0030	0.96	T6	V-Band	Free Float	N	84
		761208-0033	1.39	T6	V-Band	Free Float	N	84

Garrett
by Honeywell