

# GTX4718R

Horsepower: 900 - 1600  
Displacement: 2.5L - 10.0L

Honeywell

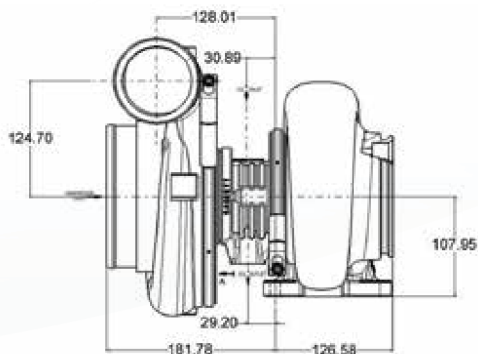

Measurements in MM



## COMPRESSOR MAP

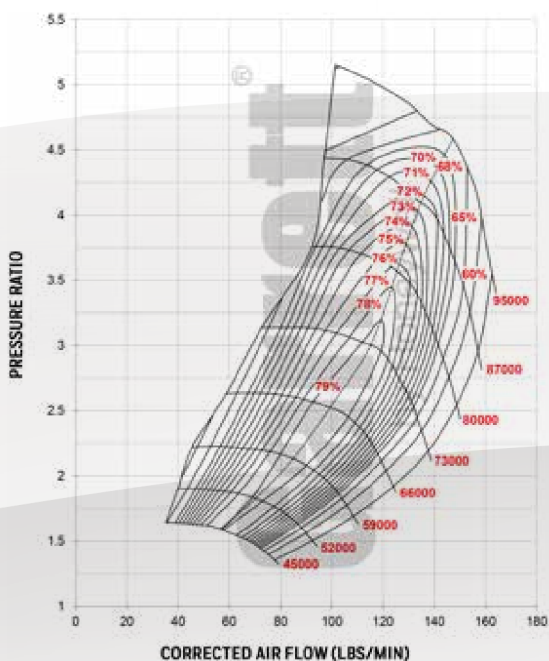

## FEATURES:

- ◆ FEATURES ORIGINAL GTX COMP WHEEL AERODYNAMICS
- ◆ NEW FULLY-MACHINED SPEED SENSOR PORT. DETAILS ON PG. 56
- ◆ SUPER CORE AND TURBINE KIT SOLD SEPARATELY
- ◆ V-BAND COMPRESSOR OUTLET CONFIGURATION
- ◆ LIGHTWEIGHT BILLET BACKPLATE

## EXHAUST FLOW CHART

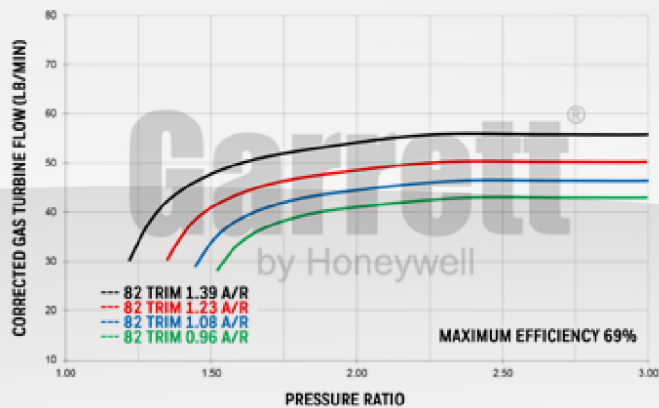

Super Core Reference Data		Compressor				Turbine		
Super Core PN	CHRA	Inducer	Exducer	Trim	A/R	Inducer	Exducer	Trim
804878-5007S	769210-0023	88mm	118mm	56	0.69	93mm	84mm	82
Notes: Super Core and Turbine Kit Sold Separately		Turbine Kit PN	A/R	Inlet	Outlet	Wastegate	Divided	Trim
		761208-0009	0.96	T6	V-Band	Free Float	N	82
		761208-0010	1.08	T6	V-Band	Free Float	N	82
		761208-0011	1.23	T6	V-Band	Free Float	N	82
		761208-0012	1.39	T6	V-Band	Free Float	N	82

**Garrett**  
by Honeywell