

# GTX2860R GEN II NEW PRODUCT

**Honeywell**

Horsepower: 200 - 475  
Displacement: 1.4L - 2.5L

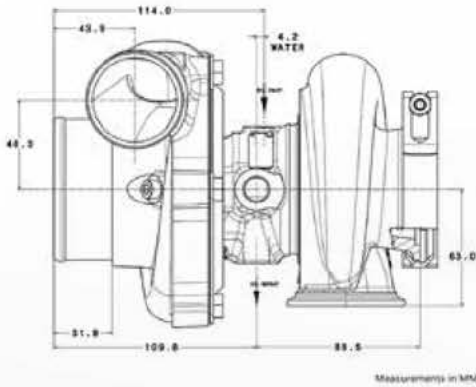

## COMPRESSOR MAP

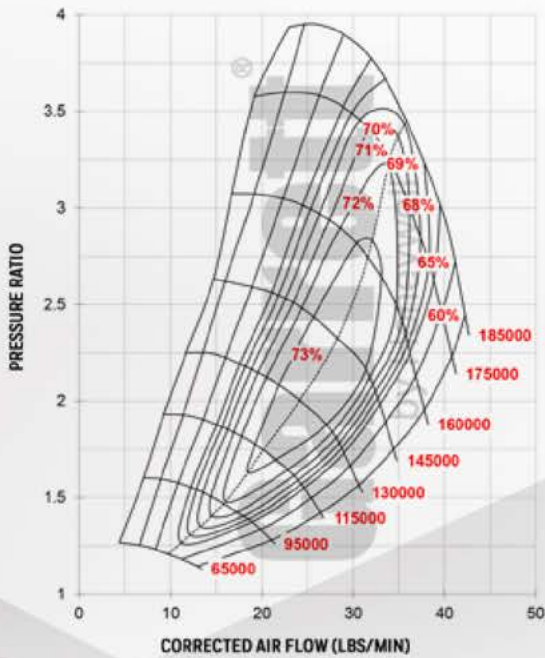

## FEATURES:

- ◆ GEN 2 AERODYNAMICS FEATURE INCREASED HORSEPOWER RANGE
- ◆ IMPROVED PORTED SHROUD DESIGN FOR SURGE RESISTANCE
- ◆ NEW FULLY MACHINED SPEED SENSOR PORT. DETAILS ON PG. 56
- ◆ WASTEGATE ACTUATORS & BRACKET KIT AVAILABLE ON PG. 56
- ◆ SOLD AS ASSEMBLY KITS (SUPER CORE + TURBINE HSG)

## EXHAUST FLOW CHART

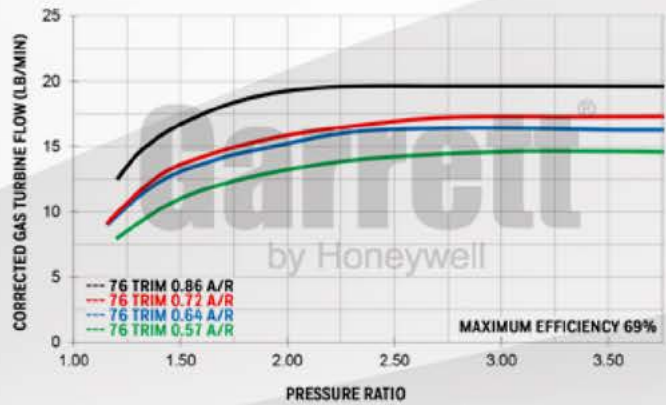

Super Core Reference Data GTX2860R		Compressor				Turbine		
		Inducer 46mm	Exducer 60mm	Trim 58	A/R 0.60	Inducer 54mm	Exducer 47mm	Trim 76
<b>Notes:</b>	<b>Assembly Kit PN</b>	<b>Super Core PN</b>	<b>Turbine Kit PN</b>	<b>A/R</b>	<b>Inlet</b>	<b>Outlet</b>	<b>Wastegate</b>	<b>Divided</b>
Assembly Kit PN Includes Super Core and Turbine Kit	856800-5003S	849894-5001S	827690-0003	0.64	T25	5 bolt	Wastegated	N
	856800-5004S	849894-5001S	827690-0004	0.86	T25	5 bolt	Wastegated	N
	856800-5001S	849894-5001S	827690-0001	0.57	V-Band	V-Band	Free Float	N
	856800-5002S	849894-5001S	827690-0002	0.72	V-Band	V-Band	Free Float	N

**Garrett**  
by Honeywell